

Awanuia



3900 DWT Bunker Tanker



General Information

Yard	Yardimci Shipbuilding, Turkey
Built	2009
Port of Registry, Flag	Auckland, New Zealand
Call Sign	ZMA 2137
Official Number	876495
Classification Society	ABS
IMO No.	9458042
MMSI No.	512219000

Dimensions

Length Overall	79.9 m
Beam, Moulded	15.0 m
Max Operating Draft	7.32 m
GRT/NRT	2747 mt/1180 mt

Accommodation	10x1 = 10 berths
----------------------	------------------

Capacities & Performance

Fuel	119,600 litres
Potable Water	165,000 litres
Sewage Treatment Plant	
Max Speed	11 knots

Cargo Capacities

HFO cargo tanks	3260 m ³
MDO cargo tanks	843 m ³

Load/Discharge Equipment

HFO Cargo Pumps	2x Twin screw (Bornemann)
Max discharge	800 m ³ /h
MDO Cargo Pumps	2x Deepwell (Marflex)
Max discharge	160 m ³ /h
Cargo Crane	1.5 mt at 22 m
Boom Hoses	6" line for HFO 4" line for MDO
Provisions Crane	3.0 mt at 6.5 m

Machinery

Main Engines	2x Wartsila 6L20
Horsepower	2900 BHP
ASD Propellers	2x Wartsila CS175-SWO-K
Bow Thruster	Schottel STT330 TLK, 300 kW
Generators	1x MAN D2842 LE 301 1x MAN D2866 LE 203

Communication Equipment

A3 + Fleet 250

PB Towage

7/F, Hutchison House, 10 Harcourt Road, Central, Hong Kong.

Tel: (+852) 2233 7000 E-mail: pbtowage@pacificbasin.com Website: www.pbtowage.com

AWANUIA

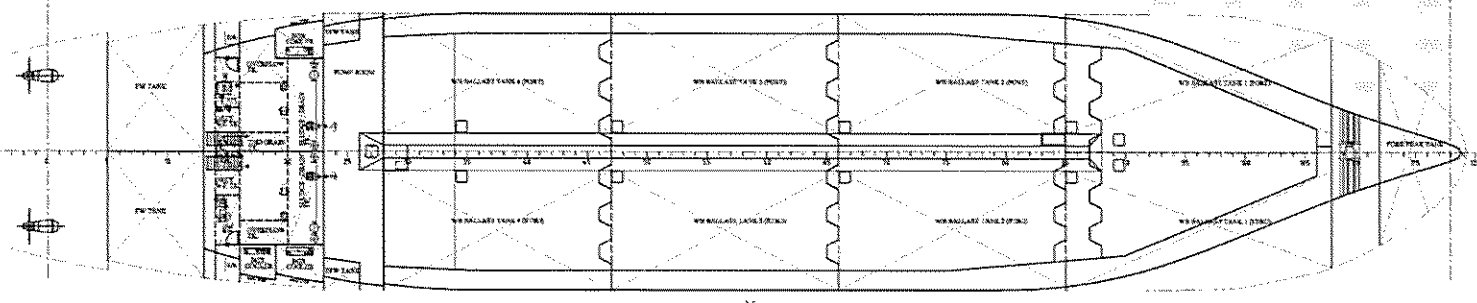
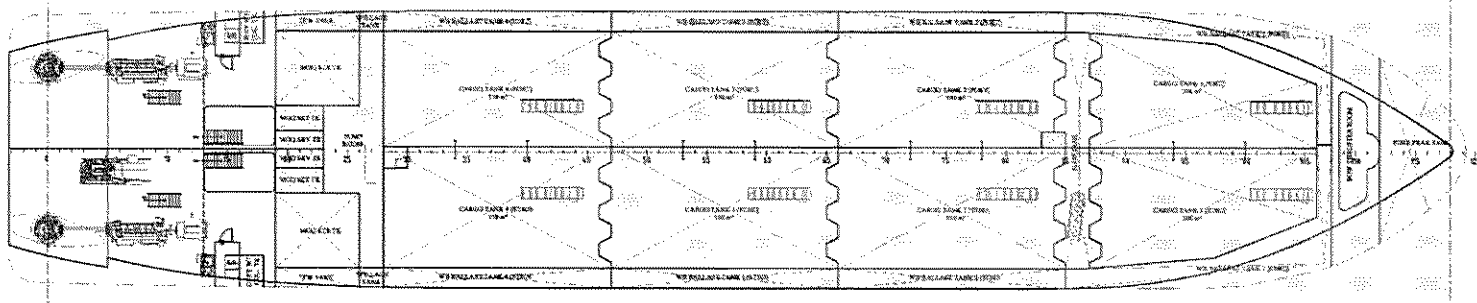
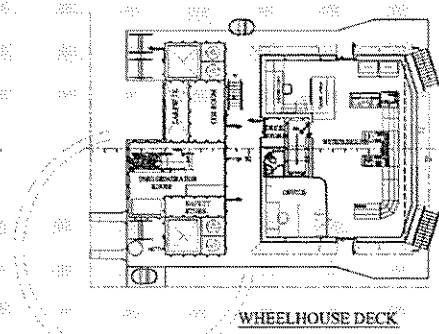
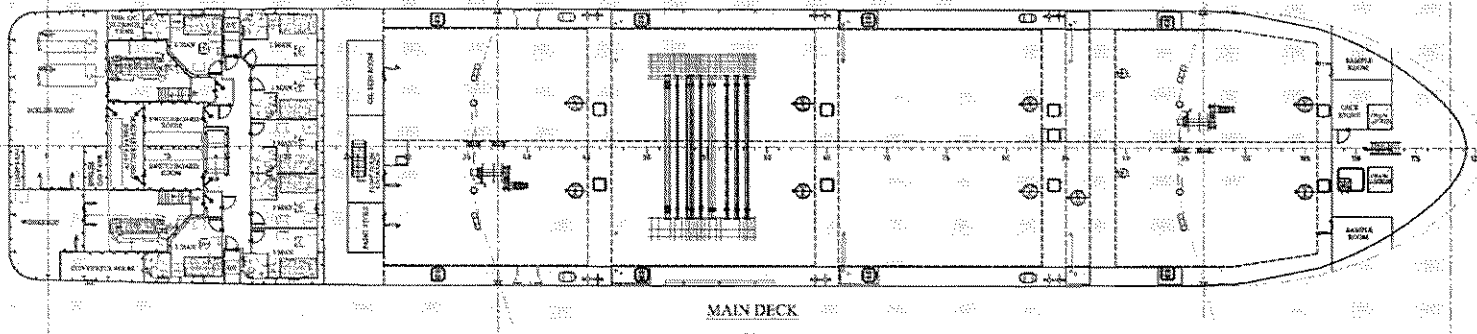
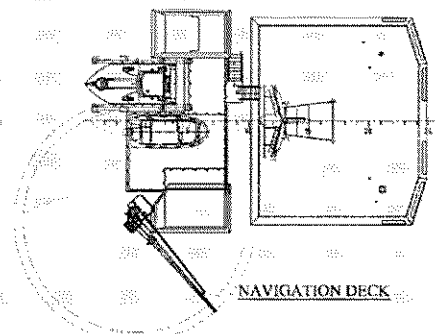
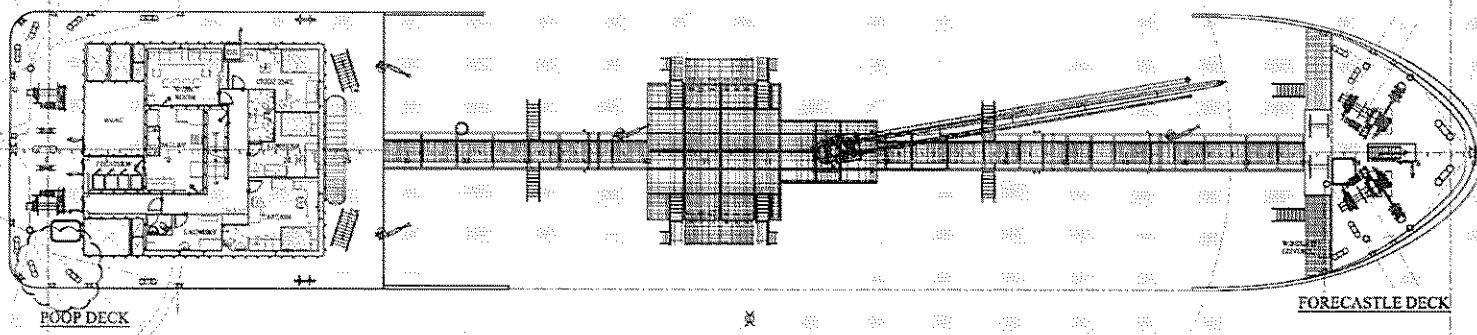
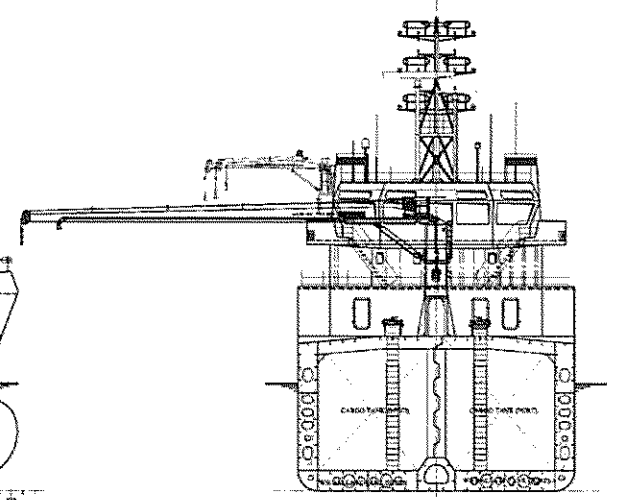
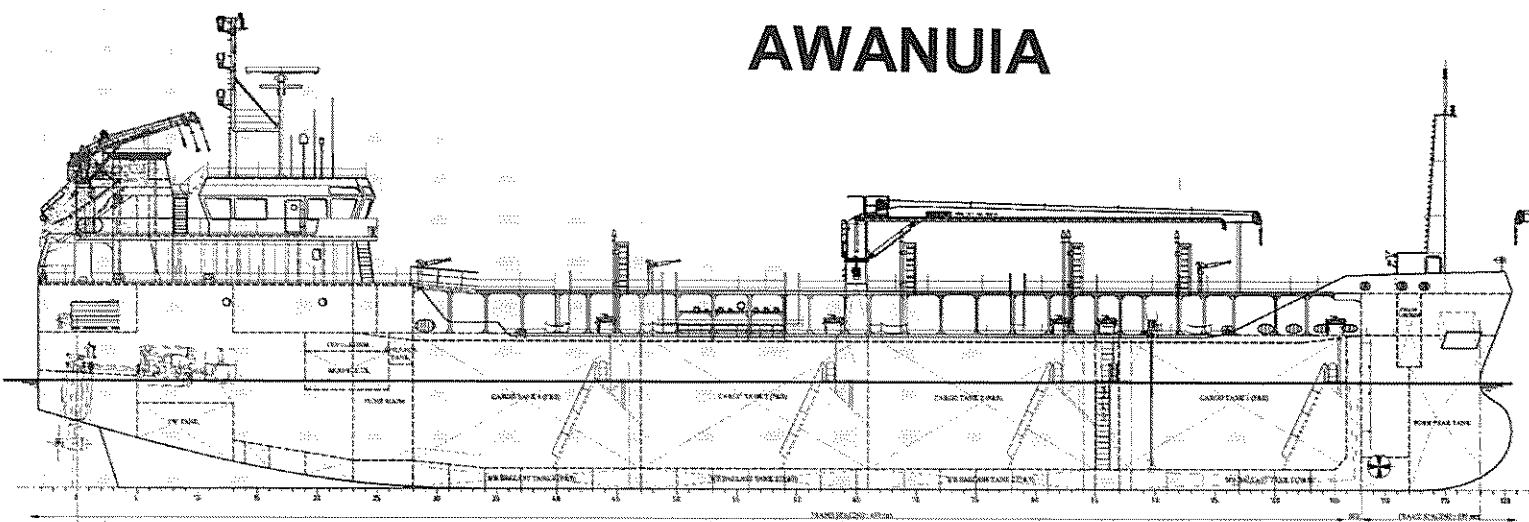

GENERAL PARTICULARS

Length Overall	79.90 m
Length Between Perp.	76.15 m
Breadth (Moulded)	15.00 m
Depth (Moulded)	8.00 m
Draught (Scantling)	6.00 m
Service Speed	11.0 kn

IMPORTANT NOTE
 *** All the rights of this project and documents related are legally protected and any document that over the is used they are used without registered permission will be non-payment.

DELTA MARINE ENGINEERING & COMPUTER TECHNOLOGIES		3900 DWT OIL TANKER	
GENERAL ARRANGEMENT			
DESIGNED BY	Yusef GÜL	OWNER	SHIPYARD
CHECKED BY	Seraf AKTAN	FOUQUET SACOP MARITIME	YARDIMCI SHEPARD
CLASS	SCALE	DATE	PROJECT NR.
D.N.V.	1:150	13.10.2004	DLT - 076
			DRAWING NR.
			100