

PB Botany



4000 BHP ASD Harbour & Ocean Towing Tug



General Information

Yard	Imamura Shipbuilding, Kure, Japan
Built	2000
Port of Registry, Flag	Sydney, Australia
Call Sign	VJN3219
Official Number	858469
Classification Society	Lloyds
IMO No.	9221401
MMSI No.	503547000

Machinery

Main Engines	2x Niigata 6L26 HLX
Horsepower	4000 BHP
Bollard Pull	54.4 mt
ASD Propellers	2x Niigata ZP-31
Winches	2x Kitagawa Kogyo, 90 T brake, Fore & Aft
Line Pull (Fore)	2 mt at 25 m/min
Line Pull (Aft)	9 mt at 10 m/min
Drum Capacities	110m x 96mm mooring line / 750m x 45 mm tow wire

Dimensions

Length Overall	29.0 m
Beam, Moulded	9.5 m
Max Operating Draft	3.81 m
GRT/NRT	297 mt/88 mt

Capacities & Performance

Fuel	134,340 litres
Potable Water	36,650 litres
Max Speed	13 knots

Accommodation 2x2 + 1x4 = 8 berths

Communication Equipment

A2

Fire Fighting

Fire Pump	1x Kashiwa CP 150-50 Diesel Driven Pump 360m ³ /hour
Fire Monitors	2x Monitors 360m ³ /hour

Updated: 12.5.10

PB Towing

7/F, Hutchison House, 10 Harcourt Road, Central, Hong Kong.

Tel: (+852) 2233 7000 E-mail: pbtowage@pacificbasin.com Website: www.pbtowage.com

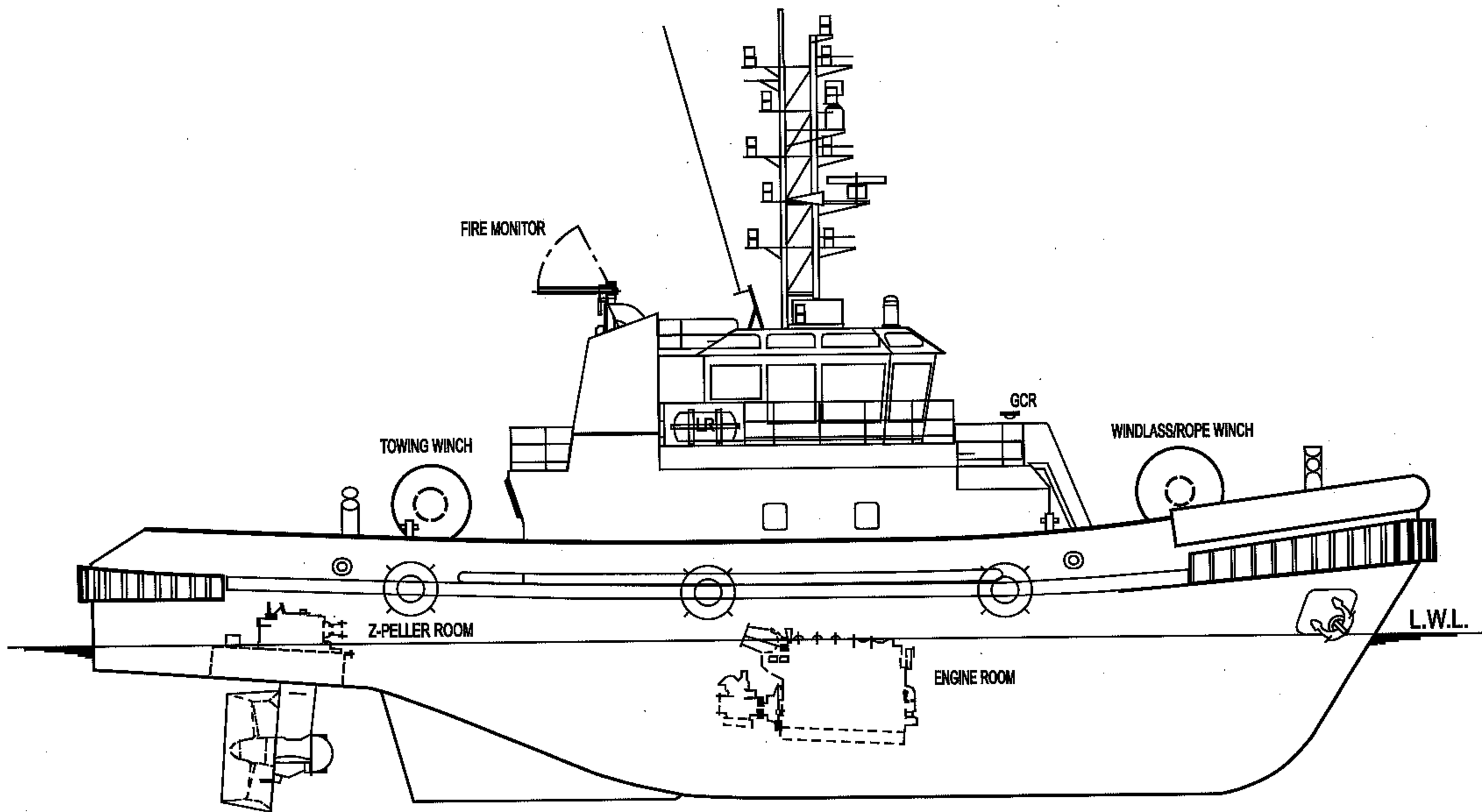

PROFILE

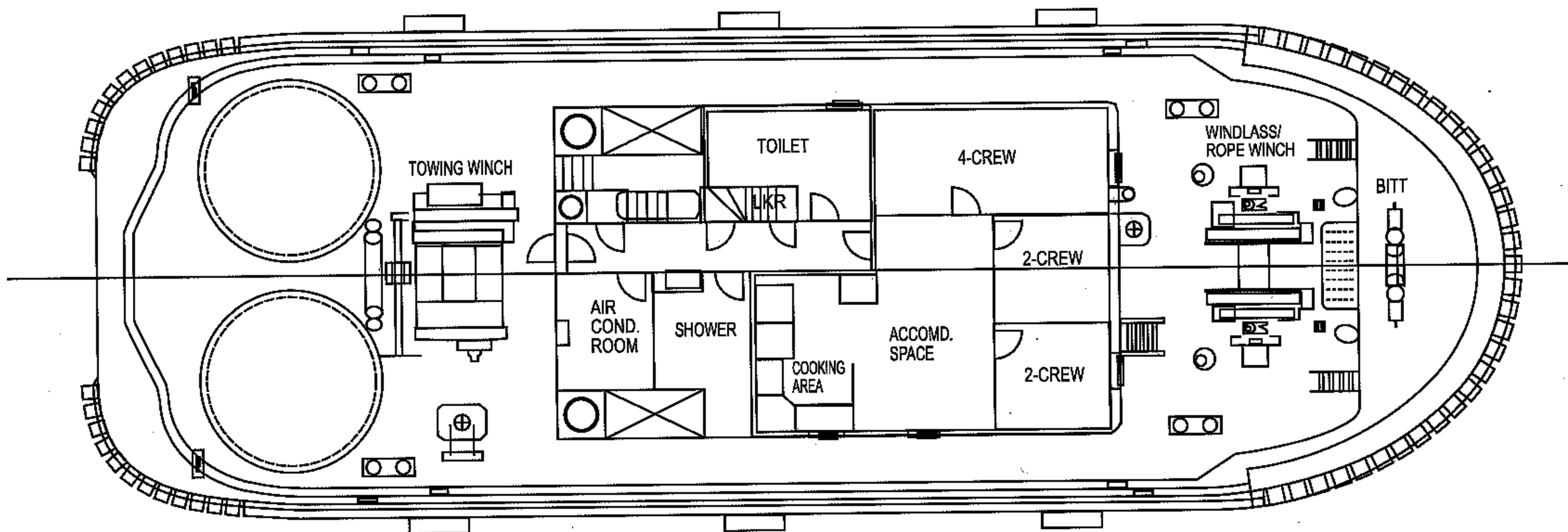

UPPER DECK PLAN

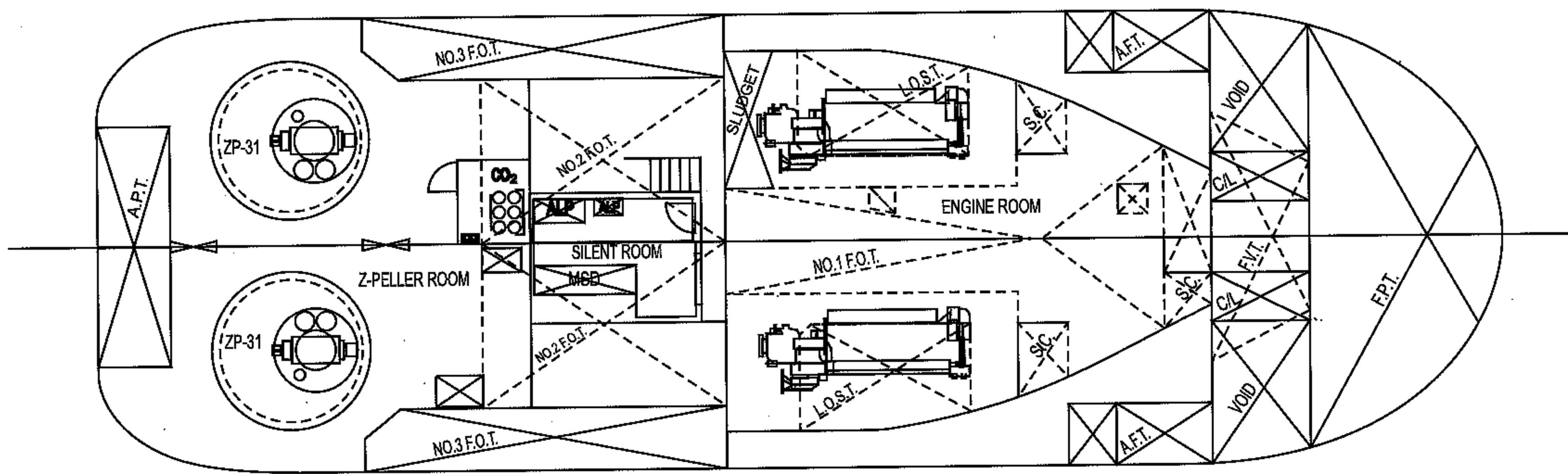

BOTTOM PLAN

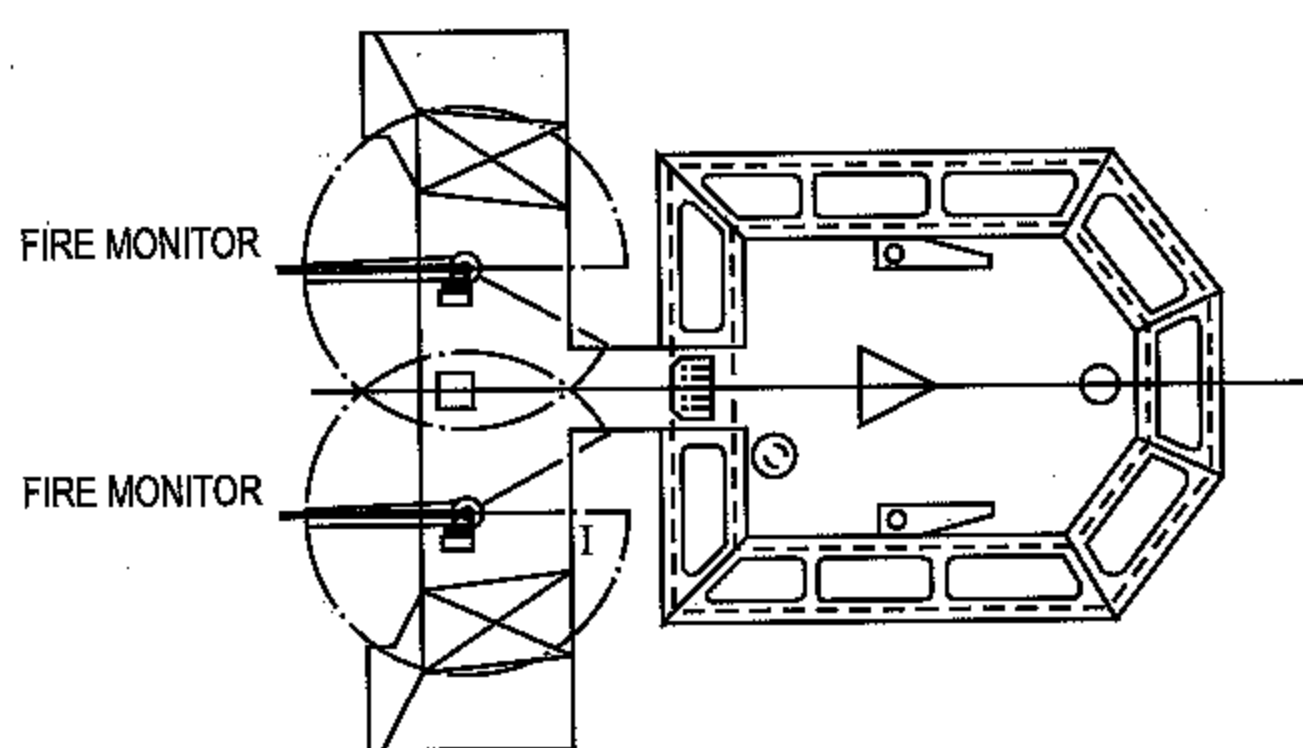

WHEELHOUSE TOP
(SHOWING PANORAMIC WINDOW LAY-OUT)

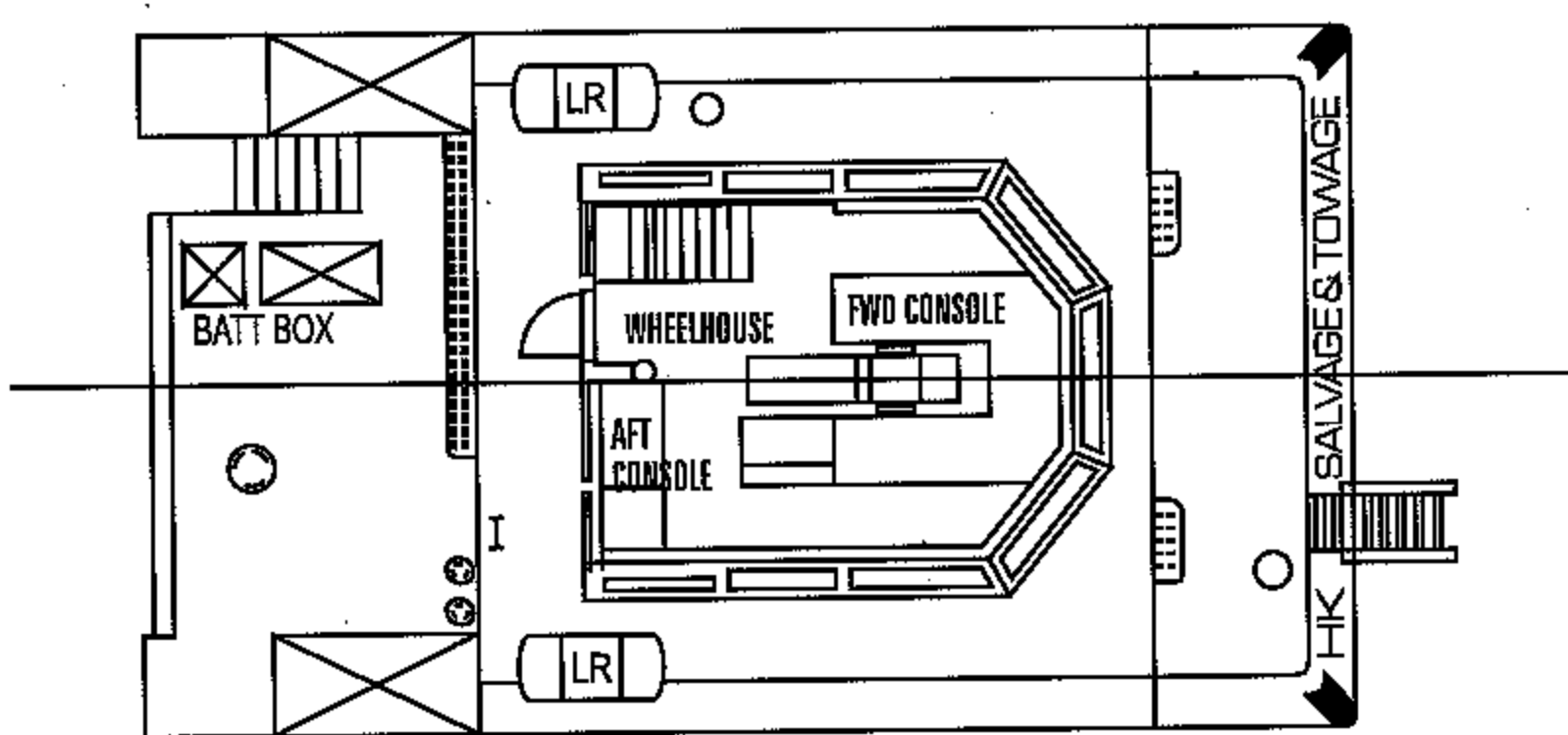

NAV. BRIDGE DECK
(FOR ONE MAN BRIDGE OPERATION)