

# PB Cook

## 4300 BHP ASD Ocean Towing & Terminal Support Tug



### General Information

Yard	Imamura Shipbuilding, Kure, Japan
Built	1994
Port of Registry, Flag	Avatiu, Cook Islands
Call Sign	E5U2227
Official Number	1311
Classification Society	Lloyds
IMO No.	9105255
MMSI No.	518277000

### Dimensions

Length Overall	34.1 m
Beam, Moulded	10.5 m
Max Operating Draft	4.31 m
GRT/NRT	456 mt/136 mt

**Accommodation** 4x1 + 3x2 = 10 berths

### Life Saving Equipment

Includes 1x Rescue boat

**Fire Fighting** FiFi ½

### Machinery

Main Engines	2x Niigata 61-28 HX
Horsepower	4300 BHP
Bollard Pull	57 mt
ASD Propellers	2x Niigata ZP-3B/K23
Fore & Aft Winches	Kitagawa Kogyo, 80 mt brake
Line Pull (Aft)	11.5 mt at 20 m/min
Aft Tow Wire	850 m x 48 mm
Line Pull (Fore)	2 mt at 25 m/min
Fore Tow Line	100m x 96mm
Tugger Winch	10 mt x 15 m/min (MacGregor)
Towing Pins	80 mt
Stern Roller	80 mt
Deck Crane	1 mt at 8 m

### Capacities & Performance

Fuel	176,000 litres
Potable Water	49,000 litres
Clear Deck Space	8.0 m x 8.5 m
Max Speed	12.5 knots

### Communication Equipment

A3 + Iridium

Updated 25.3.10

### PB Towage

7/F, Hutchison House, 10 Harcourt Road, Central, Hong Kong.

Tel: (+852) 2233 7000 E-mail: [pbtowage@pacificbasin.com](mailto:pbtowage@pacificbasin.com) Website: [www.pbtowage.com](http://www.pbtowage.com)

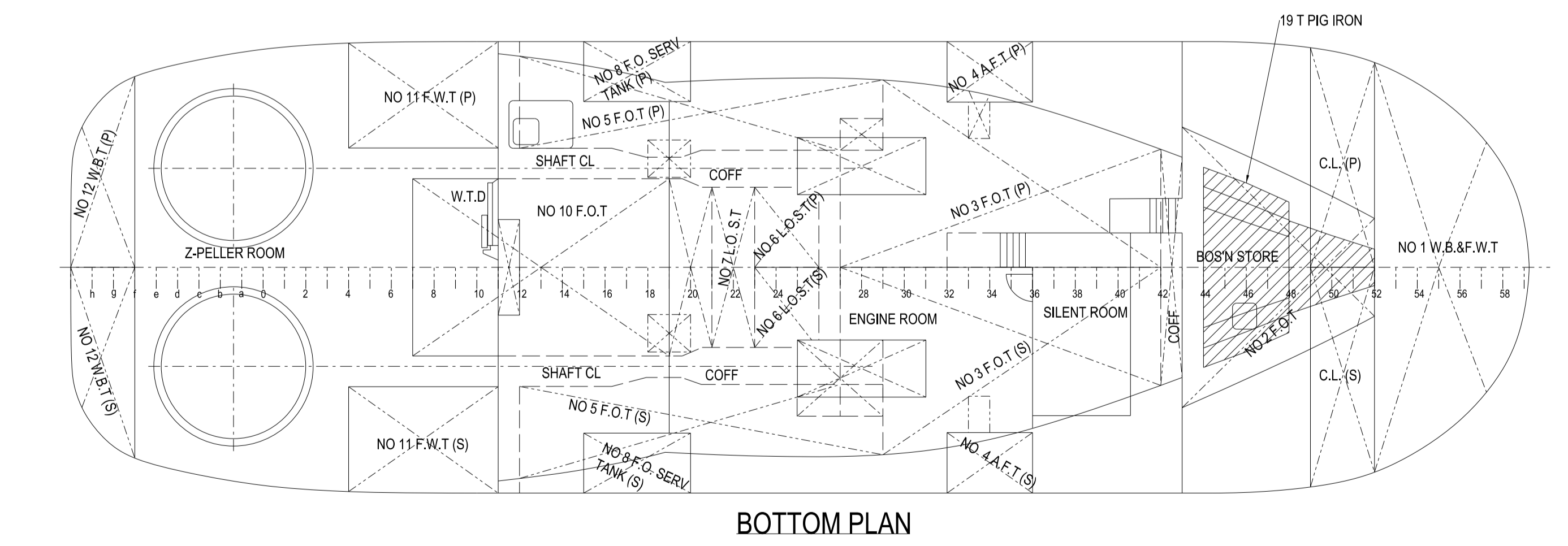
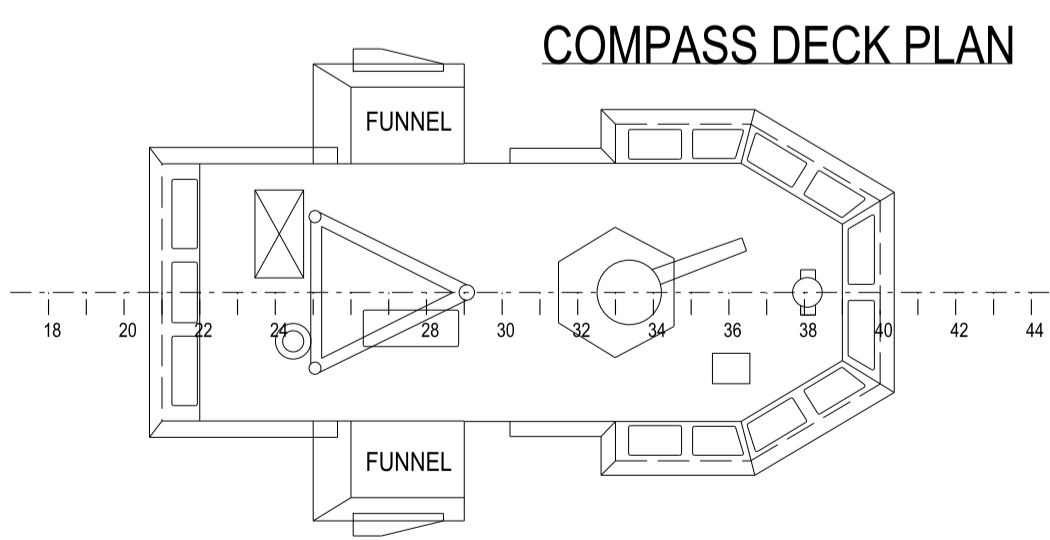
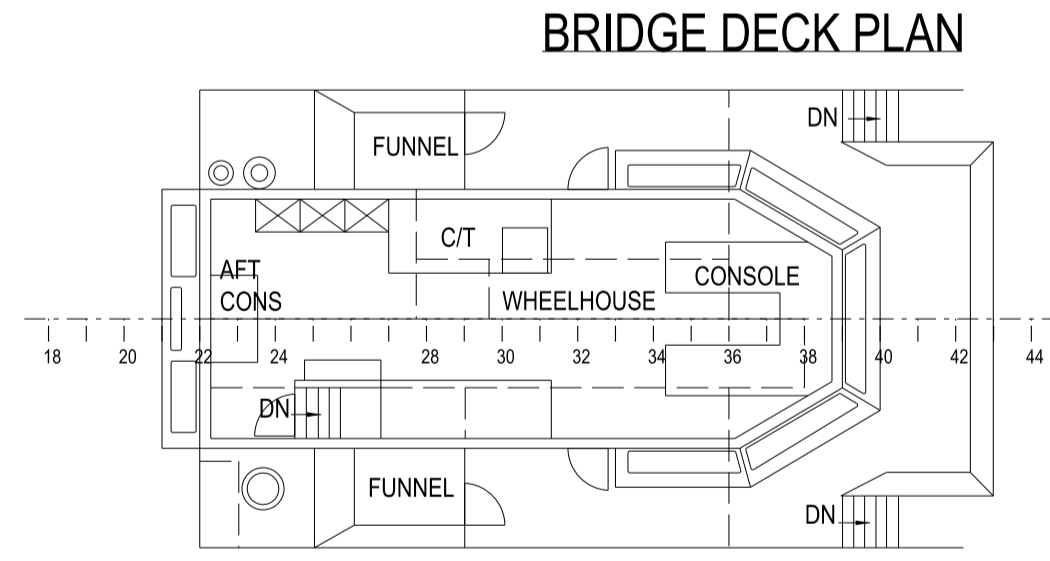
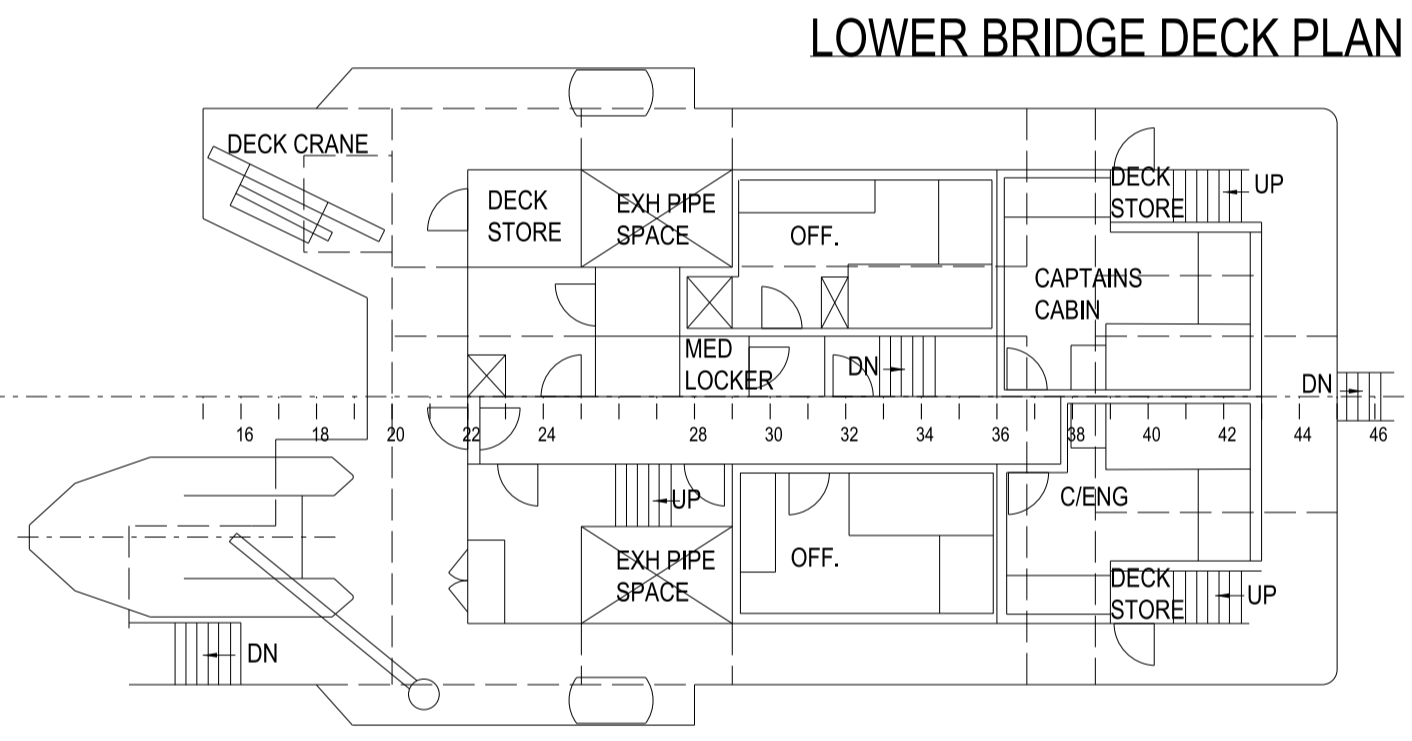
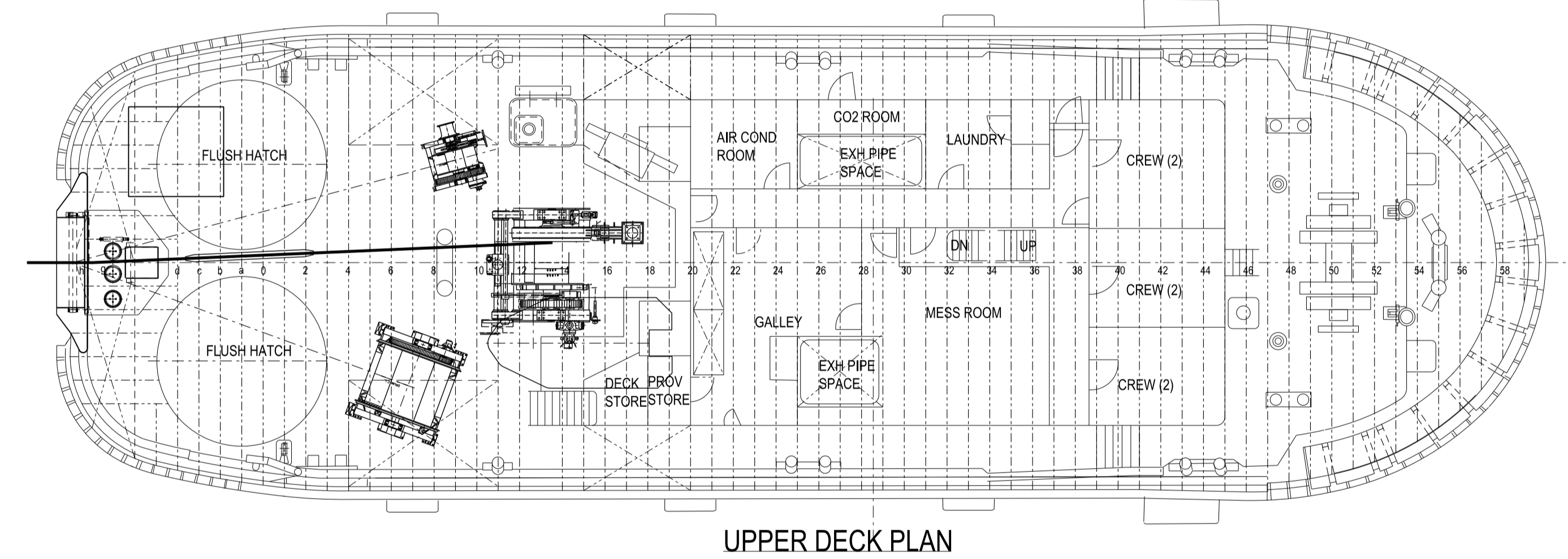
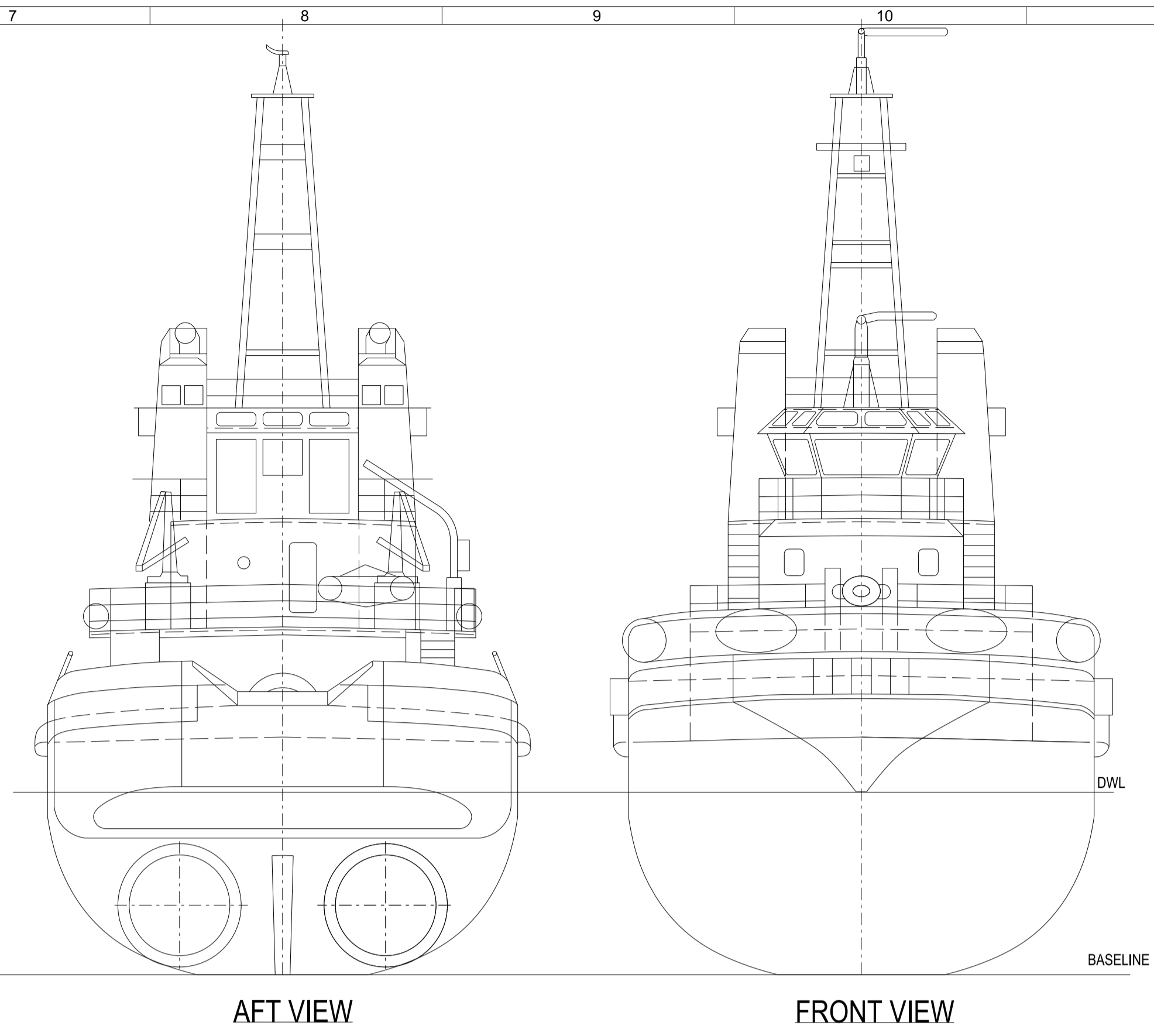
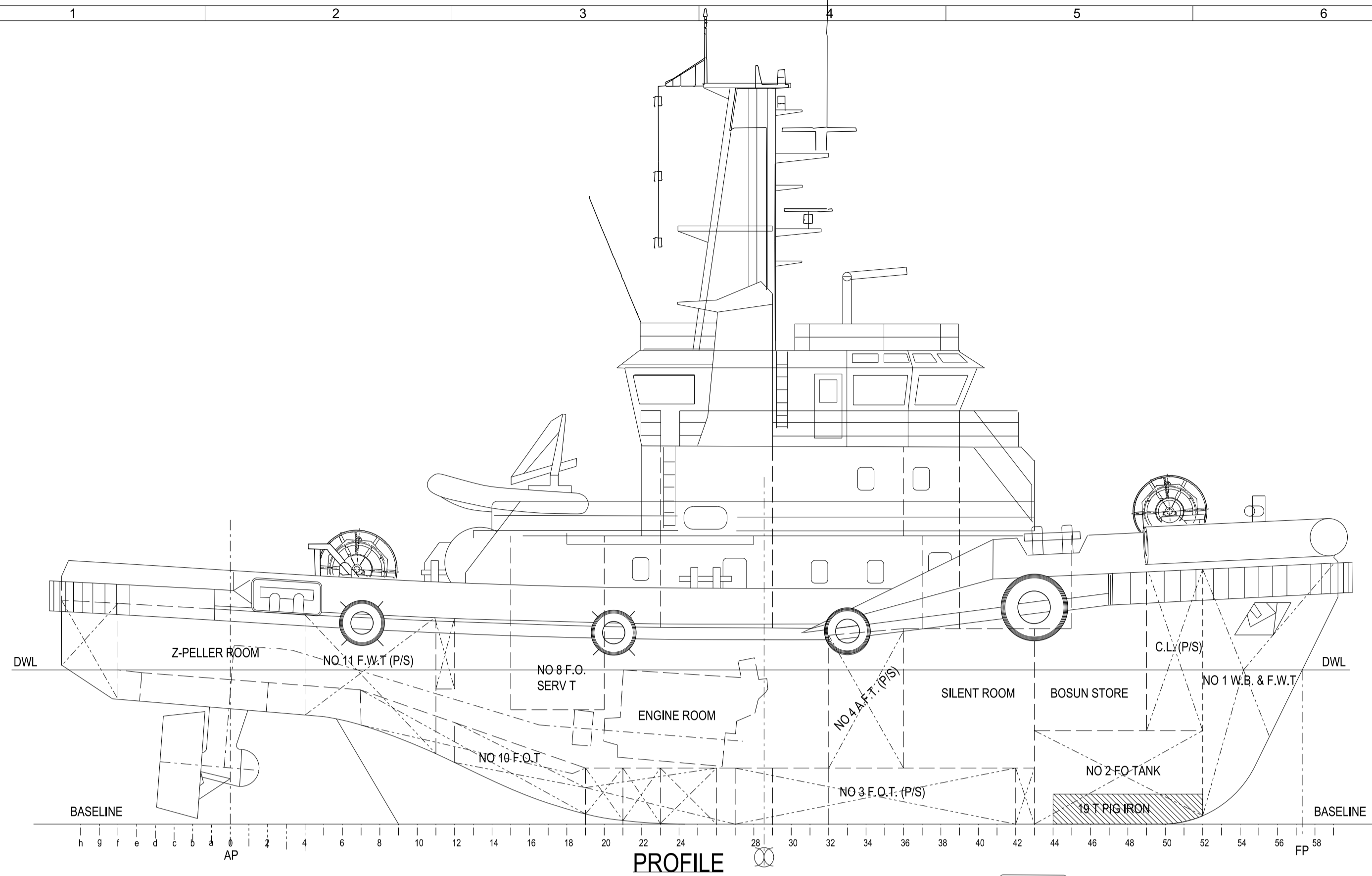

**PRINCIPAL PARTICULARS**

LENGTH OVERALL ALL (Moulded)	34.10m
LENGTH PP	28.60m
BREADTH (Moulded)	10.50m
DEPTH (Moulded)	5.20m
DRAFT (Design / Scantling)	4.10 / 4.30m
GROSS TONNAGE	456 GT
DEADWEIGHT	256.88 T

MAIN ENGINE NIIGATA 6L28HX DIESEL ENG X2 SETS  
 MCR 2000psX750rpmX2 SETS  
 PROPULSION SYSTEM NIIGATA Z-PELLER ZP-3B  
 SPEED TRIAL COND FOR MCR 13.76 knots  
 BOLLARD PULL FOR MCR 56.7 tonnes  
 COMPLEMENT 10 pers  
 CLASSIFICATION LR 100A1 , TUG LMC

**NOTES**

- THIS DRAWING BASED ON ORIGINAL SHIPS DRAWING "TS-G-001 GENERAL ARRANGEMENT BY INAMURA SHIPBUILDING 16/12/93"

 www.marinedesign.co.nz	PO BOX 3233, 0142 7 Domain Rd, Onerahi Whangarei 0110 NZ Ph: 64 9 436 4401 Fax: 64 9 436 4402	Client: <b>PB SEATOW</b>	Status: Title: <b>PB COOK          GENERAL ARRANGEMENT</b>
	PO Box 36525, 0748 46 Lake Rd, Northcote Auckland 0627 NZ Ph: 64 9 419 8440 Fax: 64 9 419 8449	Project: <b>PB COOK</b>	Scale: <b>1:100</b>
Notes	A Rev STERN ROLLER + TOW PINS + STORAGE WINCH ADDED Amendments	RSW/26.03.10 By Date Appr	Drawing No: <b>M1344-005-01</b> Rev: <b>A</b>